

INSTALLATION, SERVICE AND MAINTENANCE INSTRUCTIONS

CONTROL HEAD

C-TOP REED



10.427.32.0001



Original Instructions

10.427.30.01EN

(A) 2023/06

EC Declaration of Conformity



INOXPA S.A.U.

Telers, 60
17820 - Banyoles (Spain)

hereby declare under our sole responsibility that the

Machine: **CONTROL HEAD**

Model: **C-TOP Reed**

Type: **C-TOP Reed 24V DC 0E**
C-TOP Reed 24V DC 1E
C-TOP Reed 24V DC 2E
C-TOP Reed 24V DC 3E

Serial number: **IXXXXXXXXXX to IXXXXXXXXXX**
XXXXXXXXXXIINXXX to XXXXXXXXXXXIINXXX

fulfills all the relevant provisions of the following directive:

Electromagnetic Compatibility Directive 2014/30/EU

and with the following harmonized standards and/or regulations:

EN 61326-1:2013

The technical file has been prepared by the signer of this document.

A handwritten signature in black ink, appearing to read "DRB", written over a light gray rectangular background.

David Reyero Brunet
Technical Office Manager
8th June 2022



Document: 10.427.30.02EN
Revision: (0) 2022/06

Declaration of Conformity



INOXPA S.A.U.

Telers, 60
17820 - Banyoles (Spain)

hereby declare under our sole responsibility that the

Machine: **CONTROL HEAD**

Model: **C-TOP Reed**

Type: **C-TOP Reed 24V DC 0E**
C-TOP Reed 24V DC 1E
C-TOP Reed 24V DC 2E
C-TOP Reed 24V DC 3E

Serial number: **IXXXXXXXXXX to IXXXXXXXXXX**
XXXXXXXXXXIINXXX to XXXXXXXXXXXIINXXX

fulfills all the relevant provisions of these regulations:

Electromagnetic Compatibility Regulations 2016

and with the following designated standards:

EN 61326-1:2013

The technical file has been prepared by the signer of this document.

A handwritten signature in black ink, appearing to be 'David Reyer Brunet'.

David Reyer Brunet
Technical Office Manager
8th June 2022



Document: 10.427.30.03EN
Revision: (0) 2022/06

1. Table of Contents

1. Table of Contents	
2. Generalities	
2.1. Instructions manual.....	5
2.2. Compliance with the instructions	5
2.3. Warranty.....	5
3. Security	
3.1. Warning symbols.....	6
3.2. General safety instructions	6
4. General Information	
4.1. Description	8
4.2. Application.....	8
5. Installation	
5.1. Reception of the control head	9
5.2. Transport and storage.....	9
5.3. Identification of the control head	9
5.4. Location	9
5.5. Mechanical installation of the control head	9
5.6. Pneumatic installation of the control head	11
5.7. Electrical installation of the control head.....	12
6. Start-up	
6.1. Recommended settings	15
6.2. Positioning of the targets	15
7. Operating problems	
8. Technical Specifications	
8.1. Materials	17
8.2. Environment.....	17
8.3. Control head	17
8.4. Solenoid valves.....	17
8.5. Communication	17
8.6. Dimensions	18
8.7. Exploded drawing and parts list.....	18

2. Generalities

2.1. INSTRUCTIONS MANUAL

This manual contains information about the reception, installation, operation, assembly and maintenance of the control head C-TOP Reed.

Carefully read the instruction before starting the control head, familiarize yourself with the installation, operation and correct use of the control head and strictly follow the instructions. These instructions should be kept in a safe location near the installation area.

The information published in the instruction manual is based on updated data.

INOXPA reserves the right to modify this instruction manual without prior notice.

2.2. COMPLIANCE WITH THE INSTRUCTIONS

Not following the instructions may impose a risk for the operators, the environment and the machine, and may cause the loss of the right to claim damages.

This non-compliance may cause the following risks:

- failure of important machine/plant functions,
- failure of specific maintenance and repair procedures,
- possible electrical, mechanical and chemical hazards,
- the risk to the environment due to the type of substances released.

2.3. WARRANTY

The conditions of the warranty are specified in the General Sales Condition that has been delivered at the time of placing your order.



The machine may not undergo any modification without prior approval from the manufacturer.

For your safety, only use original spare parts and accessories. The usage of other parts will relieve the manufacturer of any liability.

Changing the service conditions can only be carried out with prior written authorization from INOXPA.

Please do not hesitate to contact us in case of doubts or if further explanations are required regarding specific data (adjustments, assembly, disassembly, etc.).

3. Security

3.1. WARNING SYMBOLS



Safety hazard for people in general and/or for the control head



Electrical hazard

ATTENTION

Important instruction to prevent damage to the equipment and/or its function

3.2. GENERAL SAFETY INSTRUCTIONS



Read the instruction manual carefully before installing and starting the control head. Contact INOXPA in case of doubt.

For a reliable and without problems function follow the instructions of this manual.

This control head cannot be used in atmospheres where exist explosion hazards.

The installation and the use of the control head always must be following the health and safety applicable regulations.

3.2.1. During installation



Always take into account the [Technical Specifications in chapter 8](#).

Use the device only for its intended use and only with the recommended equipment by INOXPA.

Before performing the installation ensure that the compressed air and the power supplies are switched off and that the actuator of the process valve is pressureless.

Ensure that the power supply does not restart.



All the electrical work should be carried out by specialised personnel.

Only use power supplies that guarantee reliable electrical isolation of the operating voltage as per IEC/DIN EN 60204-1.

Observe the general requirements for PELV circuits in accordance with IEC/DIN EN 60204-1.

Installation errors can damage the electronics or cause malfunctions.

The C-TOP Reed contains electrostatically sensitive components. Electrostatic discharge caused by improper handling or incorrect earthing can damage the internal electronics.

3.2.2. During operation



Always take into account the [Technical Specifications in chapter 8](#).

Only use the product if it is in perfect technical condition.

NEVER exceed the specified limit values.

Do not touch the inside of the control head when it is in operation.



All the electrical work should be carried out by specialised personnel.
The C-TOP Reed contains electrostatically sensitive components. Electrostatic discharge caused by improper handling or incorrect earthing can damage the internal electronics.

3.2.3. During maintenance



Always take into account the [Technical Specifications in chapter 8](#).
Before starting the maintenance work, make sure that the compressed air supply is switched off and that the air supply hoses are pressureless. Secure the system against accidental restarting.



All the electrical work should be carried out by specialised personnel.
Before starting the maintenance work, make sure that the power supplies are switched off. Secure the system against accidental restarting.

4. General Information

4.1. DESCRIPTION

The C-TOP Reed is a control head that adapts to all of the INOXPA actuators to automate pneumatic drive process valves.

The control head contains up to a maximum of three solenoid valves, two magnetic targets fix to the adapter shaft and an electronic module formed by three sensors connected to three visual indicators. (LEDs). Through external signals, the solenoid valves which control and act on the valve are activated. At the same time, the electronic module sensors can read the position of the valve actuator through the detection of the position of the targets located on the adapter shaft and they inform of the valve state with the illuminate of the control head. The control head includes DIP switches that allow obtaining different configurations of the output signals to adapt the control head to the different types of valves.

During the start-up of the control head, the targets will be positioned manually on the adapter shaft (type of the adapter shaft according to the valve) for the sensors could detect them correctly.

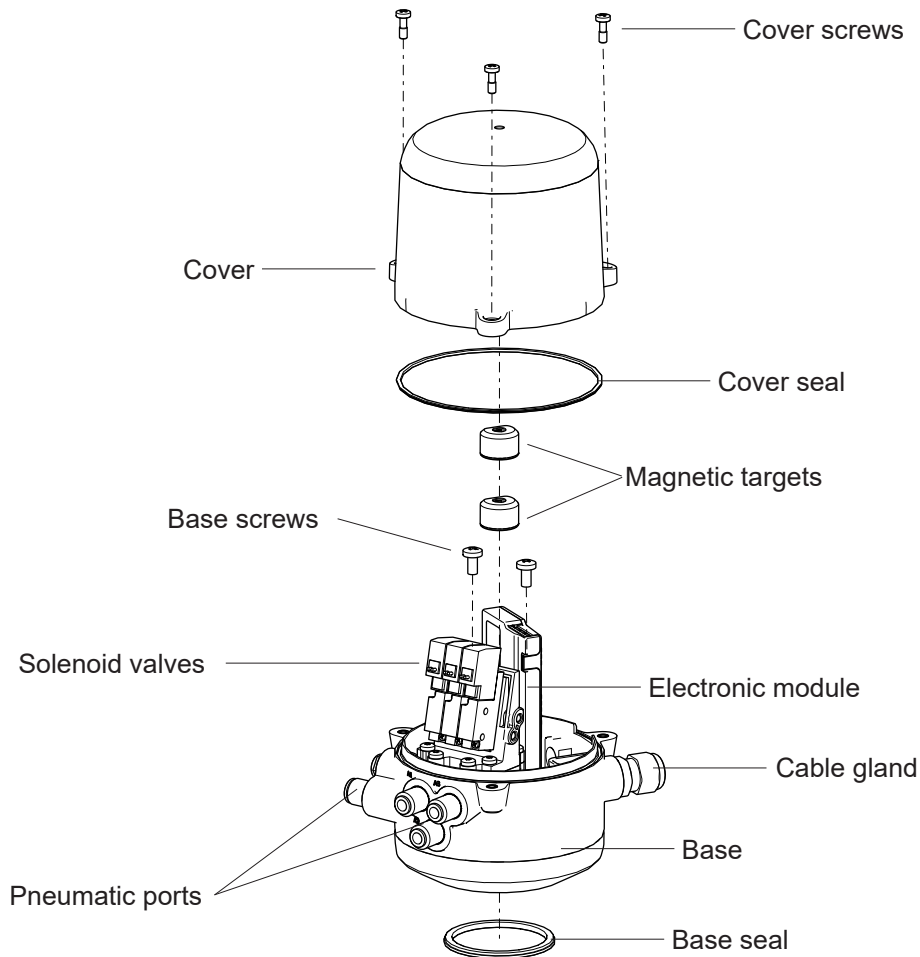

10.427.32.0004

4.2. APPLICATION

The C-TOP Reed can install on any process valve (butterfly, ball and single or double seat valves) of the food, beverage, chemical or pharmaceutical industry.

5. Installation

5.1. RECEPTION OF THE CONTROL HEAD



INOXPA is not liable for any deterioration of the material caused by its transport or unpacking.

When receipt the control head, check to see whether all the parts listed on the delivery slip are present:

- control head,
- instruction manual.

INOXPA inspects all control heads before packaging. However, it cannot guarantee that the merchandise arrives at the user intact.

When unpacking the valve:

- take all possible precautions against damage to the control head and its components,
- inspect the valve or the parts that comprise it for possible damage incurred during shipping.

5.2. TRANSPORT AND STORAGE



The buyer or user shall be liable for assembly, installation, start-up and operation of the control head.

Take all possible precautions when transporting and storing the control head to avoid damaging it and its components.

5.3. IDENTIFICATION OF THE CONTROL HEAD

Each control head is inscribed a fabrication number for its identification. Indicate the fabrication number on all documents to refer to the control head.

5.4. LOCATION

Place the control head leaving enough space around it to realize easily the dismantling, the inspection and the review of the control head. The installation should allow that the removable parts are could remove easily.

5.5. MECHANICAL INSTALLATION OF THE CONTROL HEAD



All the installation work of the control head should be carried out by specialised personnel. Always follow the instructions of the present manual. Check that the compressed air and power supply are switched off and the actuator is pressureless before starting the assembly or disassembly works.

To mount the control head on the actuator of the valve follow the next process:

1. sure that the adapter shaft of the valve is suitable for the C-TOP Reed,
2. remove the control head cover (02) by loosening the screws (01),
3. place the control head on the actuator,
4. place the two targets (10A,10B) on the adapter shaft (the type of the adapter shaft varies depending on the valve) and adjust them following the instructions of chapter 6. Start-up,
5. tighten the base screws (04) which join the head with the valve actuator.
6. place the cover (02) and tighten the cover screws (01).

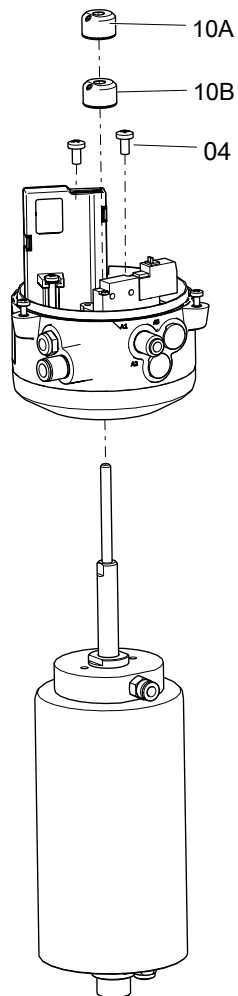

10.427.32.0011

5.6. PNEUMATIC INSTALLATION OF THE CONTROL HEAD



All the installation work of the control head should be carried out by specialised personnel. Always follow the instructions of the present manual. Check that the compressed air and power supply are switched off and the actuator is pressureless before starting the assembly or disassembly works.

The identification of the connections is on the control head.

Cut the air hoses at the needed length before starting the pneumatic installation.

To perform the pneumatic installation follow the next process:

1. connect the air hoses between air connections A1, A2 and/or A3 of the C-TOP Reed and the valve actuator's air connections,
2. connect the air supply hose to the air intake 1 of the control head,
3. connect the compressed air supply.

Connection	Description	tube outer Ø	Thread
1	supply port for operating pressure	8 mm	
3	exhaust air connection	-	
A1	working port of solenoid valve V1		G 1/8"
A2	working port of solenoid valve V2	6 mm	
A3	working port of solenoid valve V3		

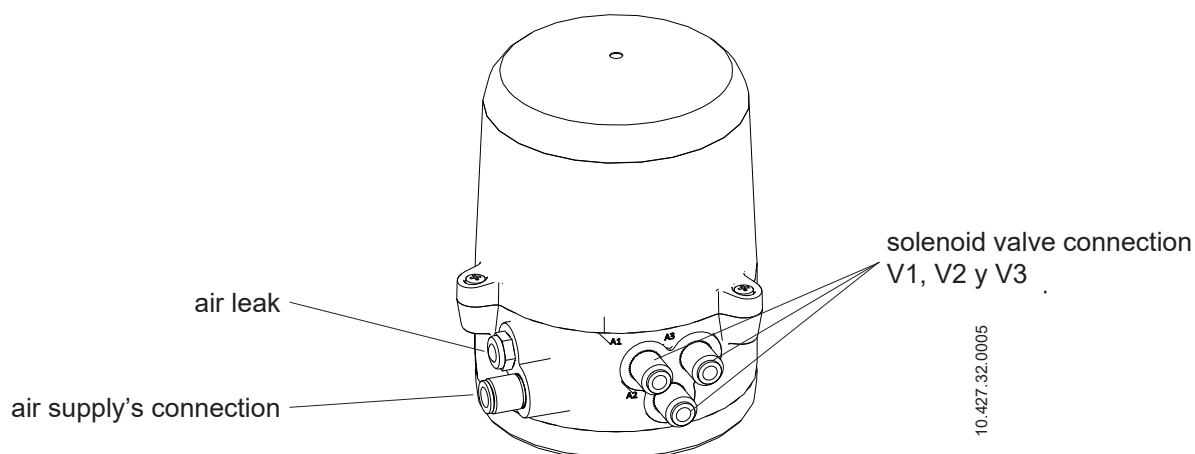

Use only approved air supply's connections and suitable quality for the installation. Cut the air connections with a suitable cutter to avoid damage to them. Use the air supply's connections with sufficient length to avoid tensions on them and to avoid its disassemble if separate the control head of the valve is needed.

5.7. ELECTRICAL INSTALLATION OF THE CONTROL HEAD



All the electrical work should be carried out by specialised personnel.
 Check that the power supplies are switched off.
 Secure the installation to prevent unintentional activation.
 The C-TOP Reed contains electrostatically sensitive components. The electrostatic discharge caused by improper handling or incorrect earthing can damage the internal electronics.

The control head C-TOP Reed is available with digital 24V DC communication for 0, 1, 2 or 3 solenoid valves.

5.7.1. Electrical installations with digital communication 24V DC

To perform the electrical installation of the control head with digital 24V DC communications follow the next steps:

1. remove the cover screws (01) of the cover (02),
2. lift and remove the cover (02),
3. route the electrical cable through the cable gland (08),
4. connect the cables to the terminal according to the wiring diagram,
5. tighten the cable gland (08),
6. place the cover (02) and fix it with the cover screws (01).

Wiring diagram digital 24 V DC communication for 0, 1, 2 or 3 solenoid valves and their outputs:

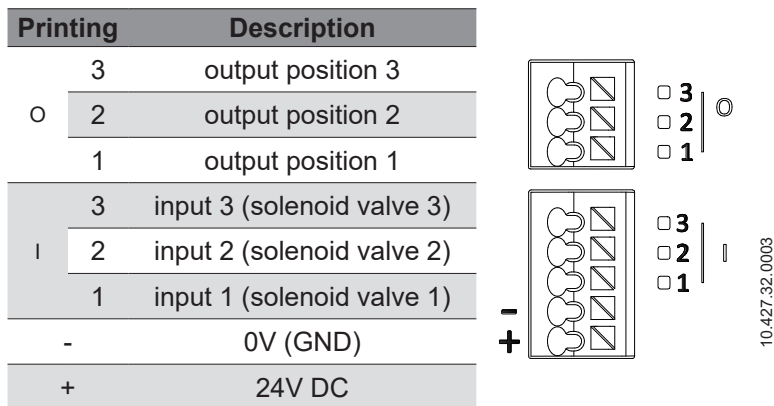

6. Start-up

The control head has three sensor located in the electronic module. Also, it incorporates DIP switches that, depending on their configuration, allow route of the output signals of the sensors.

For the start-up, the targets should be positioned manually along the shaft to be detected by the electronic module's sensors. These sensors, at a time, will activate their corresponding output illuminating the control head of the colour associated with the output activated.

The colour activated with each output are:

OUTPUT ACTIVATED	COLOUR
1	blue
2	green
3	orange

The three sensors activate different outputs according to the selected configuration. The next table details the output that activates each sensor in each configuration.

Conf.	DIP 1	DIP 2	OUTPUT 1	OUTPUT 2	OUTPUT 3
A	ON	ON	middle	upper	lower
B	OFF	OFF	lower	upper	
C	OFF	ON	upper	middle	
D	ON	OFF	upper	lower	

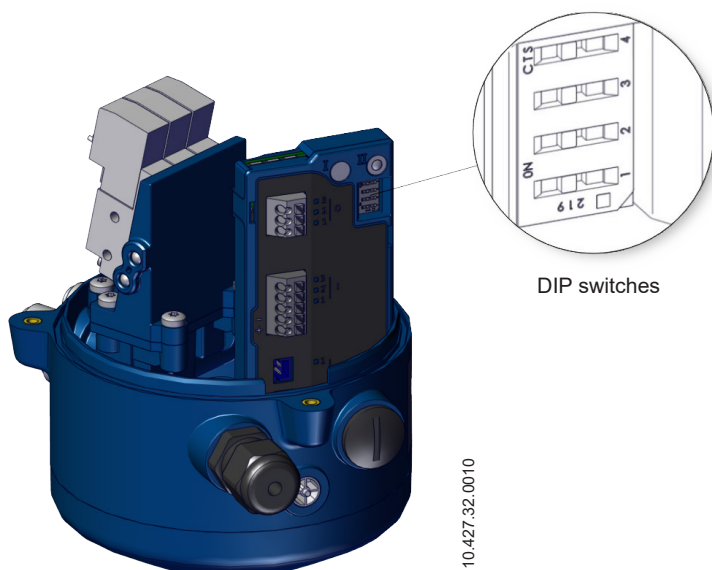
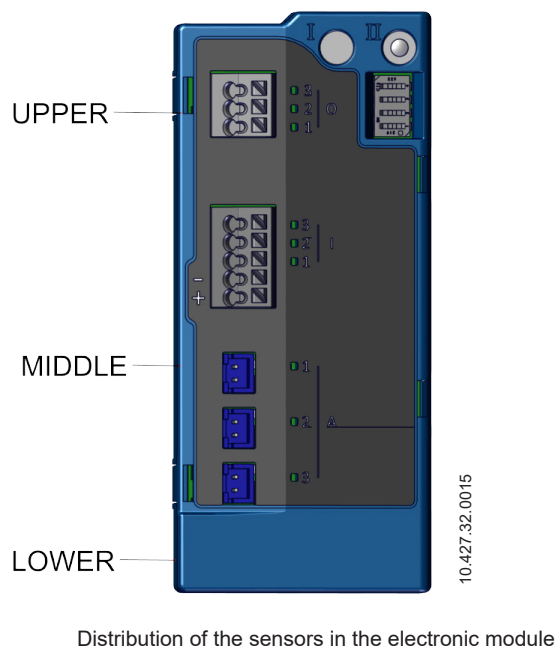

Distribution of the sensors in the electronic module

Therefore, the manner of the situate the targets will depend on the selected configuration.

The position of DIP 3 and DIP 4 is indifferent to any operating mode of the control head.

6.1. RECOMMENDED SETTINGS

The recommended settings for each type of valve are:

- quarter-turn valve: configuration B, D,
- single seat valve: configuration A, C,
- double seat valve: configuration A.

6.2. POSITIONING OF THE TARGETS

For the positioning of the targets to the adapter shaft:

1. connect the compressed air and power supply,
2. place the valve in the desired position,
3. move the first target along the adapter shaft until situate it up to the corresponding sensor (the LED of the output associated will be illuminated) and tighten the stud to fix it with Allen key number 2,
4. move the second target in the same manner as the first.

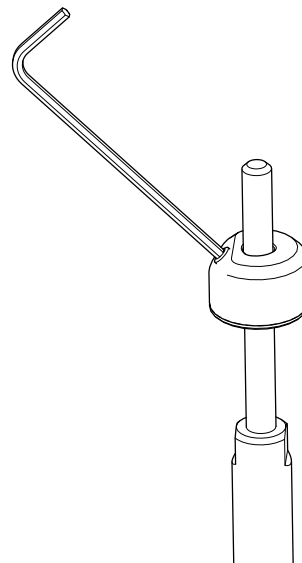

10.427.32.0013

7. Operating problems

Before doing a fault diagnosis check that the control head is correctly connected.

Fault description	Possible causes	Action
The electrical signal is NOT sent or received	The cables are defective or improperly connected	Check the electric connection and the power supply
	The electronic module is defective	Replace the electronic module
The control head NOT be illuminated	Sensor break	Replace the sensor
	Wrong position of the target	Do again the positioning of the targets
The valve NOT activate	The solenoid valve doesn't receive the external signal	Check the electric connection
	Solenoid valve break	Replace the solenoid valve
Wrong operation of the process valves	The pneumatic connections are not correctly connected	Check that each pneumatic hose is connected to the corresponding output of the control head

8. Technical Specifications

8.1. MATERIALS

Plastic parts	PA6
Screws	A2
Seals	NBR
Air fittings	nickel-plated brass

8.2. ENVIRONMENT

Outdoor use	C1 - protected areas
Storage temperature	-20°C to 50°C
Environment temperature	-5°C to 50°C
Degree of protection	IP65, IP67

8.3. CONTROL HEAD

Stroke	≤ 70 mm
Maximum shaft diameter	22 mm
Adapter shaft diameter	6 mm
Assembly type	screws
Fluid	filtered compressed air, filtration degree 40 µm lubricated or not lubricated
Measuring principle	magnetic Reed type
Measured quantity	position
Detection range	± 5 mm
Visual indicators	LED

8.4. SOLENOID VALVES

Quantity	0 - 3
Type	3/2 way, normally closed with manual locking
Operating pressure	3 -7 bar
Operating voltage	24 V DC ±10%
Power consumed	0,35 W

8.5. COMMUNICATION

Digital 24 V DC	
Operating voltage	24 V DC ± 10%
Outlets	PNP normally open
Terminal	push-in type, nominal cable section 0,2 to 1,5 mm ² (22 AWG to 16 AWG)
Main input	cable gland M16 x 1,5 (4 to 10 mm diameter cable)

8.6. DIMENSIONS

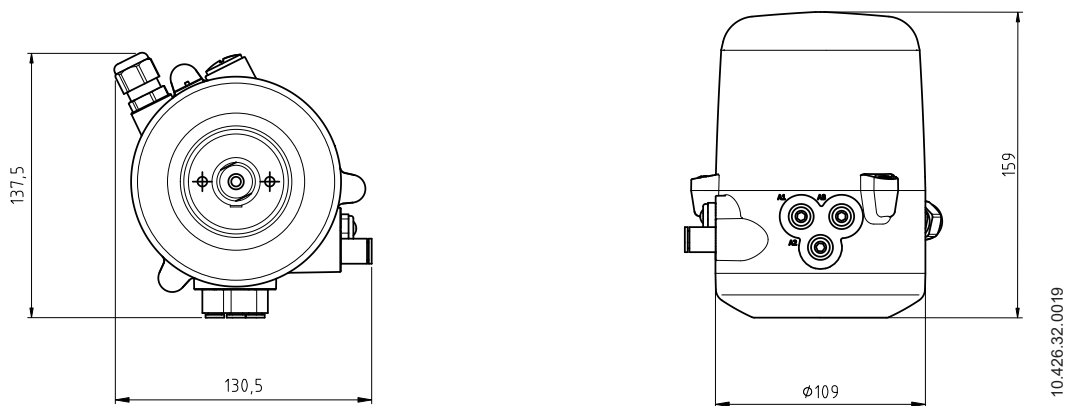

8.7. EXPLODED DRAWING AND PARTS LIST

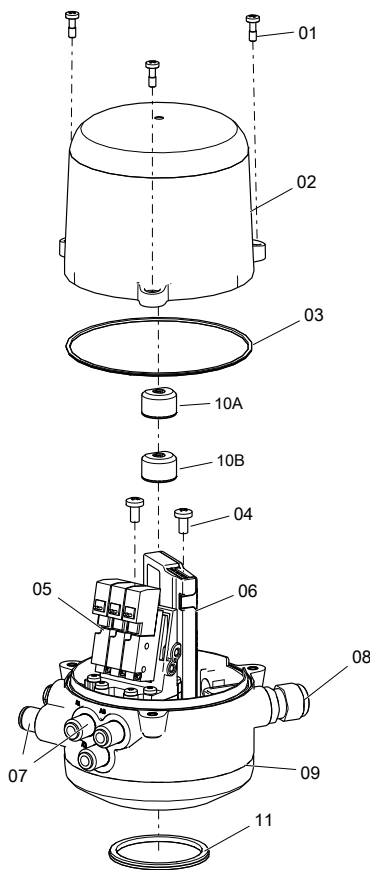

10.427.32.0007

Position	Description
01	cover screws
02	cover
03	cover seal
04	base screws
05	solenoid valves
06	electronic module
07	pneumatic ports
08	cable gland
09	base
10A	upper target
10B	lower target
11	base seal

NOTES

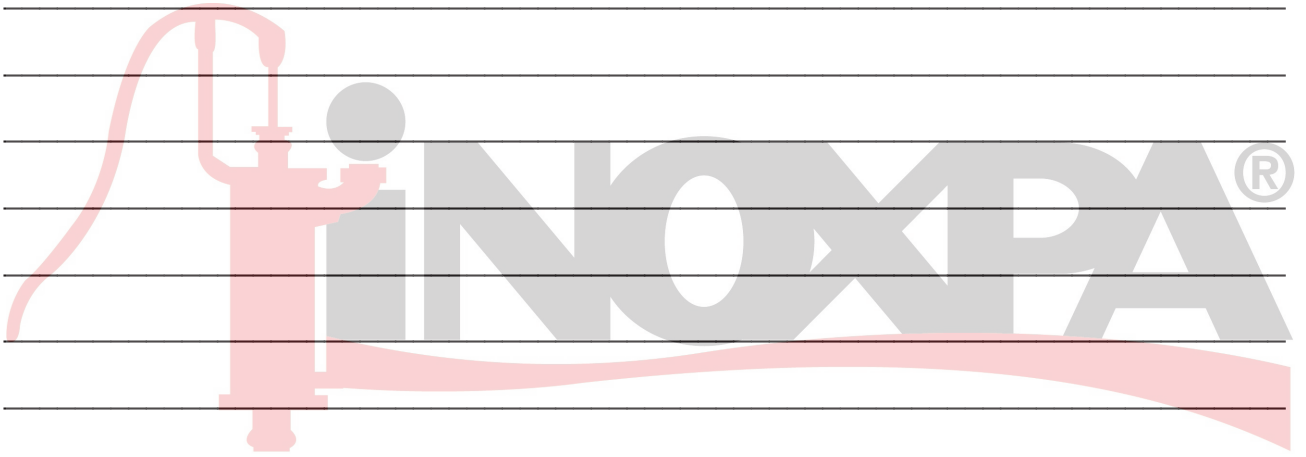

How to contact INOXPA S.A.U.:

Contact details for all countries are continually updated on our website

Please visit www.inoxpa.com to access the information.



INOXPA S.A.U.
Telers, 60 - 17820 - Banyoles - España

